

SECTION A-A

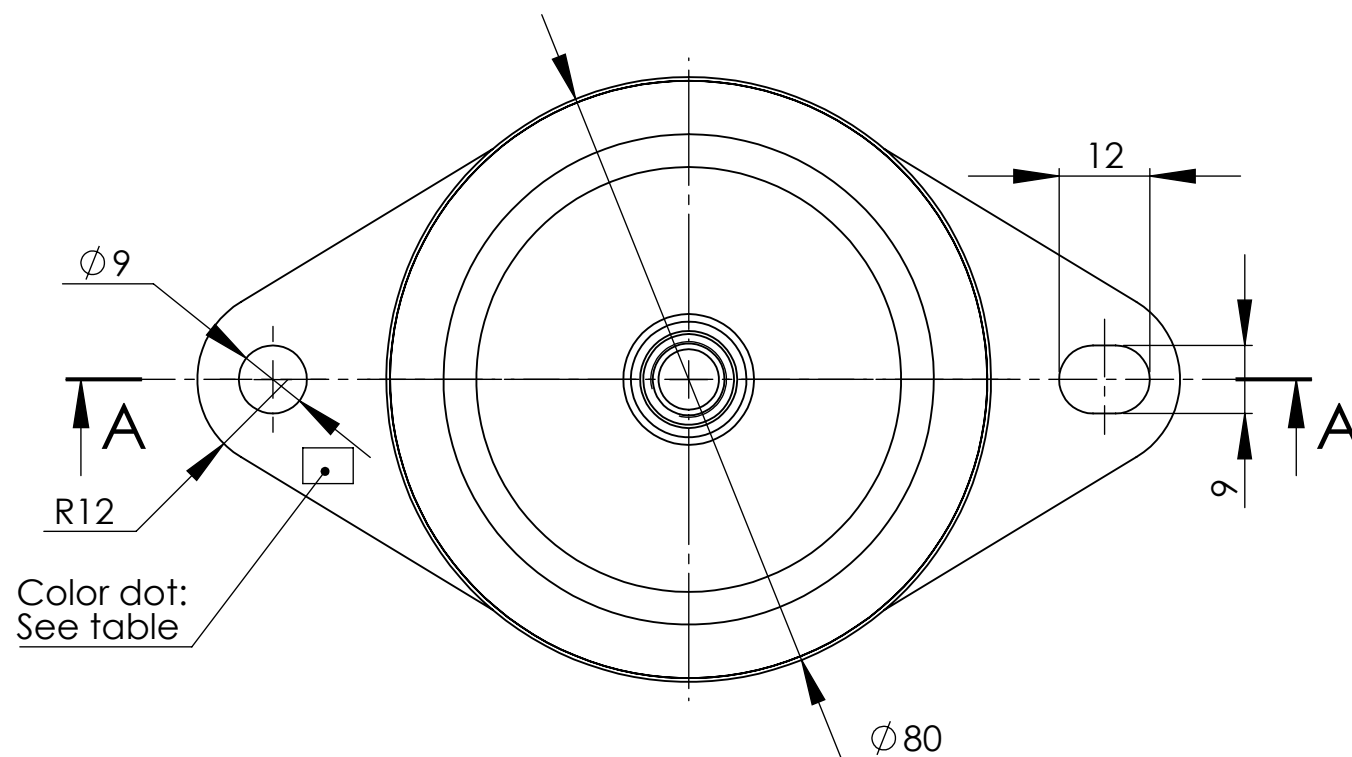

(1.) Only for information.

(2.) Corrosion protection:
DIN 50979 Fe//Zn8//Cn//T0, Salt spray test min 120 h.

SAP number	Mould number	Color dot	Vertical stiffness c [N/mm] ±20 %	Vertical permitted constant load F [N]
4000013123	786230	Black	315	950
4000013124	786230-S1	Blue	680	1900
4000013125	786230-S2	White	425	1300

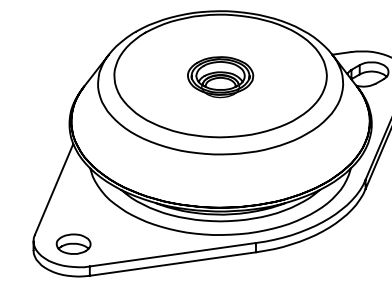

Only the English language version of the text is binding

Refer to protection notice ISO 16016	General tolerances ISO 2768-mk ISO 3302 M3
Tolerancing principle SIZE ISO 14405 (E)	Lengths, radii, chamfers
First angle projection ISO 5456-2	Angles
Edges ISO 13715	Straightness, flatness
Surfaces ISO 1302	Circularity, circular/total runout
Surface calculated [mm ²]	Parallelism, perpendicularity
Volume calculated [mm ³]	Symmetry

Mould Number: See table **Code: See table**

Scale:	Drawn		R&D Changshu SolidWorks
1:1	Checked		Format A3
	Approved		



Name:
**Machine Mount
(Customer drawing)**

Replace for:
Belongs to:
Drawing no.:
CN15-0366